

MICROSTRUCTURED OPTICAL FIBRES: WHY USE POLYMERS?

Maryanne Large (1),

Alexander Argyros (1,2), Geoff Barton (3), Ian Bassett (1), Felicity Cox (1,2), Matthew Fellow (1,2), Geoffrey Henry (1), Nader Issa (1,2), Steven Manos (1,2), Whayne Padden(1), Leon Poladian (1), Martijn A van Eijkelenborg (1), Joseph Zagari (1,3)

1 : Optical Fibre Technology Centre, Australian Photonics Cooperative Research Centre, University of Sydney, 206 National Innovation Centre, Australian Technology Park, Eveleigh NSW 1430, Sydney, Australia
Email:M.Large@ofc.usyd.edu.au

2 : School of Physics, University of Sydney, Sydney, NSW 2006, Australia

3 : Department of Chemical Engineering, The University of Sydney, NSW 2006 Australia

Abstract *Microstructured fibres made from polymer can bring new functionality in terms of the variety of structures that can be produced and the type of material that can be incorporated into the fibre.*

Introduction

Microstructured optical fibres (also known as "Photonic crystal fibres" or "holey" fibres) were first developed in 1996 [1] and have subsequently generated enormous interest. Important features associated with such fibres are their ability to remain single-moded over a very large frequency range [2], to be single-moded with a large mode area [3], and the ability to guide light in air [4]. Modifications of the hole structure have allowed a number of specialty applications to be realized, for example highly birefringent or polarization maintaining fibres [5]. Their dispersion properties have also attracted attention [6], particularly because of the possibilities they offer for dispersion compensation. By changing the core size of the fibres, it is also possible to make them have either very low or very high optical non-linearity. A recent use of this property was the development of a fibre system for supercontinuum generation [7].

Until 2001 all microstructured optical fibres had been fabricated in glass, our group has succeeded in producing microstructured polymer optical fibre for the first time [8]. Very shortly after this result was published a Korean group made a similar announcement at the Polymer Optical Fibre Conference in Amsterdam [9].

Glass microstructured fibres are made using a method based on capillary stacking. This results in structures that reflect the stacking properties of the capillaries, generally having either hexagonal or square lattices. The method therefore limits the size, geometry and packing properties of the holes. Using Microstructured Polymer Optical Fibres (MPOFs) we have shown that we can produce almost arbitrary hole structures [10].

From a materials perspective too, MPOF opens up new possibilities. In glass fibres, the possibilities for modifying the properties by doping are limited both by the high processing temperatures

(2000° C), which cause many materials to decompose, and the need to avoid phase separation. All organic materials, such as dyes for example decompose above 400° C. The polymer samples we have used in tests so far are drawn at 175° C. By use of surfactant or block co-polymer techniques, it is also possible to obtain substantial quantities of inclusions.

Experimental Methods

Extruded Polymethylmethacrylate (PMMA) preforms with a Tg of 115 °C were used for exploratory experiments. This material has relatively poor optical quality. The issues associated with material and scattering losses are currently being addressed. Preforms can be either monolithic [ie have all the holes within a single piece of polymer], or assembled by stacking capillaries and sleeving. Complex structures can be assembled by combinations of multiple-holed capillaries and stacking techniques. Further fabrication details are included in an upcoming publication [11].

The fibres are drawn at a rate of a few m/min at a constant high tension. Fibre diameter uniformity of $\pm 1 \mu\text{m}$ is achieved over tens of metres of fibre by a feedback control loop between the capstan speed and the fibre diameter monitor. At the drawing temperature, the surface tension of PMMA is $\sim 0.032 \text{ N/m}$ and the viscosity $\sim 5 \times 10^6 \text{ Pa}\cdot\text{s}$. This compares favourably with the equivalent values for silica glass commonly used to fabricate silica photonic crystal fibre, where the values are respectively $\sim 0.30 \text{ N/m}$ and $\sim 3.6 \times 10^6 \text{ Pa}\cdot\text{s}$ at the draw temperature. In addition to the more favourable values of surface tension and viscosity, polymer chain alignment effects [12] contribute to make the MPOF draw process robust to deformation, and to allow non-circular shapes to be maintained during the draw. MPOF must be drawn relatively cold and under high tension if the microstructure is to be maintained. As a result, the fibres are often brittle after the draw, and may be hard to cleave. Annealing under tension has been

shown to alleviate these problems.

Novel MPOF structures

We have pioneered the use of novel structures that cannot be easily made by conventional techniques in glass. One area that has been explored extensively is the use of ring structures rather than the hexagonal packing generally found in glass fibres. These are fibres in which the holes are arranged in concentric rings. Such fibres have been fabricated by our group [10] and are of immediate interest. Ring structured fibres approximating Bragg fibres offer an approach to fabricating air-guiding MPOFs which may be simpler to make than conventional designs because they are essentially one dimensional. Unpublished results indicate these fibres are less sensitive to variations in hole position than conventional photonic crystal fibres.

Ring structures also present the opportunity to produce an air-core fibre design that supports a single, circularly symmetric, polarization non-degenerate mode [13,14]. Such fibres use the Brewster condition to suppress the TM mode, and cannot be fabricated using conventional approaches, as conditions on the refractive indices in the fibre are not satisfied by any materials currently used in optical fibres.

Another advantage of ring structures is that they allow interpenetrating holes which make it possible to produce reasonable approximations to graded index fibres. One such fibre is shown below, in Figure 1. Such structures may be of great interest for LAN applications, where a large core size is essential for easy connectorisation, while the graded index helps to ensure desirable dispersion properties.

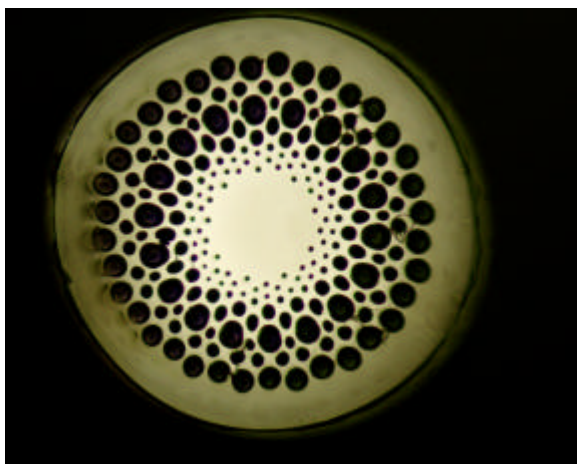

Figure 1: a Graded Index Microstructured Polymer Optical Fibre or GIMPOF.

Highly birefringent fibres are another application where MPOF may have key advantages. The easy processability of polymers ensures that it is simpler to make elliptical holes, and the more favourable surface tension means that the holes are more likely to stay elliptical during the draw. We are exploring a number of approaches to produce and maintain ellipticity in the microstructure. Figure 2 shows an intermediate stage [cane] of the draw process of such a fibre. The holes become more circular as the fibre is drawn to smaller diameters.

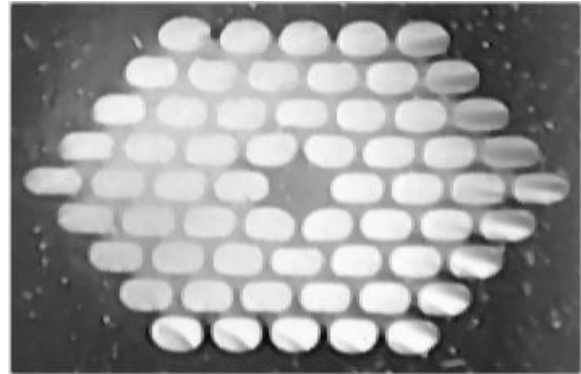

Figure 2: Elliptical holes are one approach being explored as a route to highly birefringent fibres.

Modelling and Optimisation

The greater variety of structures that can be fabricated in MPOF has led us to develop new approaches to modelling and fibre design. We have developed new algorithms that allow us to model structures of arbitrary geometry and calculate confinement loss [15,16]. Using this approach we have been able to calculate the properties of structures that cannot be easily obtained by other methods. For example we have used it to explore the properties of fibres with elliptical holes, including the beat length and polarisation dependent loss [Figure 3 (a) and (b).]

The approach is sufficiently robust and efficient that we have been able to use it in an automated fashion. This has allowed us to develop the use of evolutionary strategies for fibre design [17,18]. Given the extremely large parameter space available in MPOF design, this approach may be vital in fully exploring the new opportunities afforded to us.

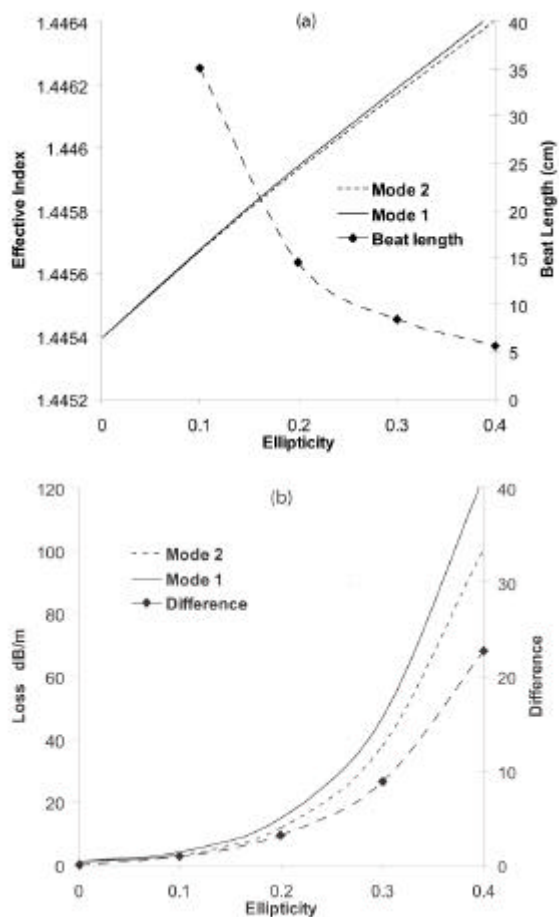

Figure 3. Calculations of the properties of birefringent microstructured fibres with elliptical holes.

Fibre Poling and the Use of Novel Materials

The material properties of polymer fibres have not previously been explored as widely as they might have been because of the requirement for single mode fibres for many applications. In conventional polymer fibres this is problematic. Diffusion in polymers occurs at relatively low temperatures, and most step index polymer fibres are made with two different polymers. The core/cladding refractive index difference in these fibres is normally much greater for similar glass fibres, and the core size required to achieve single mode operation is correspondingly small and hard to fabricate. The MPOF approach however makes single-modedness straightforward. This may allow the greater material diversity possible with polymers to be utilised in applications such as sensing.

An area that has attracted considerable attention in the past has been the use of electrically poled fibres, which would have a variety of applications including switches and non-linear optical applications. Polymers have been developed for the electro-optic effect for many years, and the long interaction length

possible in fibres makes them particularly suitable for use in this area. We have developed a technique for incorporating tungsten electrodes into the fibre during the draw process. The technique is illustrated in Figure 4.

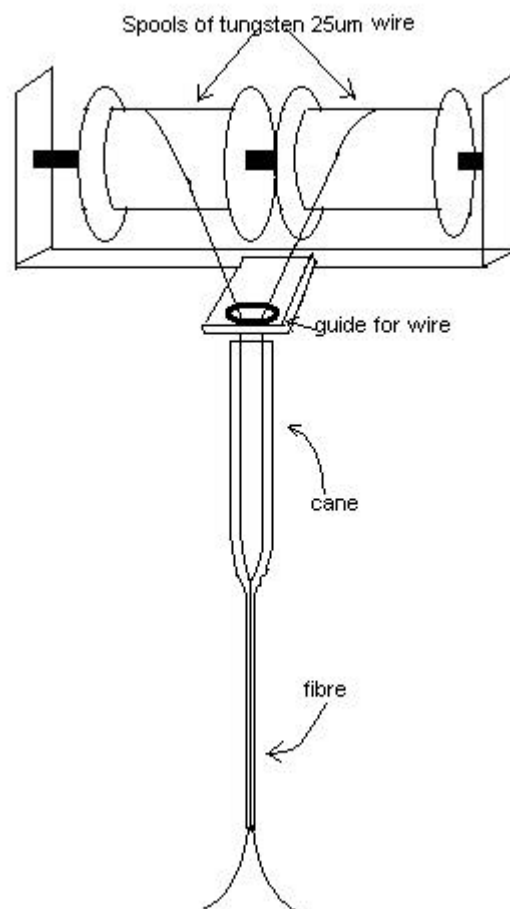

Figure 4: A method for incorporating electrodes into MPOF during the draw process.

Drawing the electrodes into long lengths of fibre can be done reliably and easily. An example is shown in Figure 5.



Figure 5: An MPOF incorporating 25 micron electrodes.

The microstructure can be easily distorted during the draw however, and care must be taken to ensure the correct draw conditions and fibre design. Our preliminary results indicate a small electro-optic effect in undoped PMMA. The measured value was $\sim 0.04\text{pm/V}$, and is probably due to charge trapping. We are continuing to optimise the technique and investigate the process more fully.

We have also recently begun work on doped PMMA samples and have incorporated dyes such as Disperse Red and Rhodamine 6G. Similarly, we have begun to work on high/low refractive index polymer microstructures rather than polymer/air microstructures. One approach we are investigating is filling the holes with a liquid polymer during the draw, which can subsequently cured. While this work is very preliminary, it offers enormous scope, particularly for poling experiments, where poling could occur while the inclusion was in the liquid phase, and be frozen in subsequently.

Conclusions

It is already clear that MPOF opens up new possibilities for polymer fibres, both in terms of the variety of microstructures and the materials that can be incorporated into the fibres. Challenges remain to optimise fibre performance, particularly with regard to loss.

Acknowledgements

We acknowledge the Australian Research Council, the Australian Photonics CRC, Redfern Photonics and Cactus Fiber for funding of this work. We also gratefully acknowledge the contribution of our colleague Barry Reed to the fibre fabrication process.

References

1. Knight, J.C., T.A. Birks, P.St.J. Russell, and D.M. Atkins, *Opt. Lett.* 21, No. 19, 1547-1549 (1996).
2. Birks, T.A., J.C. Knight, and P. St. J. Russell, *Opt. Lett.* 22, 961 (1997).
3. Knight, J.C., T.A. Birks, R.F. Cregan, P.St.J. Russell, and J.-P. de Sandro, *Electron. Lett.* 34, 1347 (1999).
4. Cregan, R.F., B.J. Mangan, J.C. Knight, T.A. Birks, P.St.J. Russell, P.J. Roberts, and D.C. Allen. *Science* 285, 1537 (1999).
5. Steel, M. J and Osgood R. *MOpt. Lett.* 26, 229-231 (2001).
6. Knight, J.C., Arriaga J, Birks T. A, Ortigosa-Blanch A., Wadsworth W. J., and Russell P. St. J., *IEEE Photon. Tech. Lett.* 12, No. 7, 807-809 (2000).
7. Ranka, J., Windeler R. S., and Stentz A. J., *Opt. Lett.* 25, 25 (2000).
8. van Eijkelenborg M. A., Large M. C. J., Argyros A., Zagari J., Manos S., Issa N. A, Bassett I., Fleming S., McPhedran R. C, de Sterke C. M. and Nicorovici N.A.P., *Optics Express*,9(7), 319-327, September 2001.
9. Choi J., Kim D. Y., Peak U.C, Proceedings of the Plastic Optical Fibres Conference, Vrije Universiteit, Amsterdam, 27-30 September 2001, pp355-360.
10. Argyros A., Bassett I.M., van Eijkelenborg M. A., Large M. C. J., Zagari J., McPhedran R. C., and Nicorovici N. A. P.,*Optics Express* Vol. 9, No 13 (2001)
11. M A van Eijkelenborg, A Argyros, G Barton, I M Bassett, M Fellow, G Henry, N A Issa, M C J Large, S Manos, W Padden, L Poladian, J Zagari, to appear in *Optical Fiber Technology*, Vol. 9, No. 4. (2003).
12. Goh C. J., Phan-Thien N., Proceedings of the Institution of Mechanical Engineers. Part E, *Journal of process mechanical engineering*, 204, 81-86 (1990)
13. A. Argyros, I.M. Bassett, M.A. van Eijkelenborg, M.C.J. Large, R.C. McPhedran. In *Holey Fibres and Photonic Crystals, IEEE LEOS Summer Topicals 2003, Fairmont Waterfront, Vancouver, BC, Canada*, 14-16 July, 2003.
14. A. Argyros, I. Bassett, M. van Eijkelenborg, M. Large. In *Australian Conference on Optical Fibre Technology ACOFT, Hilton on the Park, Melbourne, Australia*, 13-16 July, 2003.
15. L Poladian, N. A. Issa, and T. M. Monro, *Optics Express* Vol. 10, No. 10, Page 449-454 (2002)
16. N. Issa and L. Poladian, to appear in *J. Lightwave Tech.* 21 (4), (2003).
17. S. Manos and L. Poladian, *Australasian Conference on Optics, Lasers and Spectroscopy*, December 3-6, Brisbane, Australia.
18. S. Manos and L. Poladian, 4th *Asia-Pacific Conference on Simulated Evolution and Learning*, November 18-22, Singapore, 2002.